



The Sudden Storm][Kit by QRPme

The Sudden Storm kit is a simple, easy-to-build direct conversion receiver based on a design by the Rev. George Dobbs, G3RJV, presented in his Practical Wireless column. QRPme's version of the circuit board is designed to fit on top of a tuna can creating the perfect mate for the Two Tinned Tunas kit. With no coils to wind, a minimum of parts and a step by step pictorial builder's guide, this kit is ideal for beginners and experienced builders alike.

W1REX QRPme www.QRPme.com

Manual Ver. 5.0



Open the can and the adventure begins...

Organize the parts and take an inventory...

Hopefully, everything is there and you can get started!

Sudden Storm][Parts List

R1 = 100K (brn-blk-yel)	C1 = 68pf axial (680)	D1 = 1N4005
R2 = 10 ohms (brn-blk-blk)	C2 = 220pf axial (221)	D2 = 1N4005
R3 = 22 ohms (red-red-blk)	C3 = .01uf axial (104)	D3 = 1N5818
R4 = 10K (brn-blk-org)	C4 = .01uf (104)	D4 = 1N4148
R5 = 680 ohms (blu-gry-brn)	C5 = .01uf (103)	
R6 = 27K (red-vio-org)	C6 = .33uf (334)	Q1 = 2N7000
R7 = 100K (brn-blk-yel)	C7 = .1uf (104)	VR1 = LM7809ACZ
JMPR = 0 ohms (black)	C8 = .1uf (104)	U1 = 8pin DIP
P1 = 10K potentiometer	C9 = 100pf (101)	socket & SA612
P2 = 10k potentiometer	C10 = 100pf (101)	U2 = 8pin DIP
	C11 = .1uf (104)	socket & LM386
L1 = 10uh (brn-blk-blk)	C12 = 100uf	P1 = 2pin .1" Molex
L2 = 10uh (brn-blk-blk)	C13 = .1uf (104)	J1 = RCA jack
	C14 = .33uf (334)	J2 = RCA jack
1/8" x 1 1/2" bolt & nut	C15 = 10uf	14 pin IC carrier
printed circuit board	C16 = .01uf (103)	XTAL = 7.030
tuna can	C17 = 100uf	& 7.040
	C18 = .1uf (104)	8pin SIP strip
	C19 = 100uf	
	C20 = .01uf (103)	

When building up an electronic circuit board, there are several different techniques for determining the order of parts placed on the board:

center of board working towards edges

left to right for right handed builders

right to left for left handed builders

short to tall components

groups of like parts: resistors, capacitors, diodes etc.

Each technique has a logic to its own. This builder's guide uses a combination of groups of like parts AND shorter more close to the board parts first then increasingly taller and bulkier parts.

So the parts that are closest to the board are resistors and diodes. Install all the resistors first followed by the diodes.

- R1 & R7 = 100K (brn-blk-yel)
- R2 = 10 ohms (brn-blk-blk)
- R3 = 22 ohms (red-red-blk)
- R4 = 10K (brn-blk-org)
- R5 = 680 ohms (blu-gry-brn)
- R6 = 27K (red-vio-org)

- D1 & D2 = 1N4005
- D3 = 1N5818
- D4 = 1N4148 or 1N914

The monolithic ceramic capacitors are next.

- C4, C5, C20 = .01uf (103)
- C6, C14 = .33uf (334)
- C7, C8, C11,
C13, C16, C18 = .1uf (104)
- C9, C10 = 100pf (101)

Install the 2 TO92 devices next.

- VR1 = LM7809ACZ
- Q1 = 2N7000

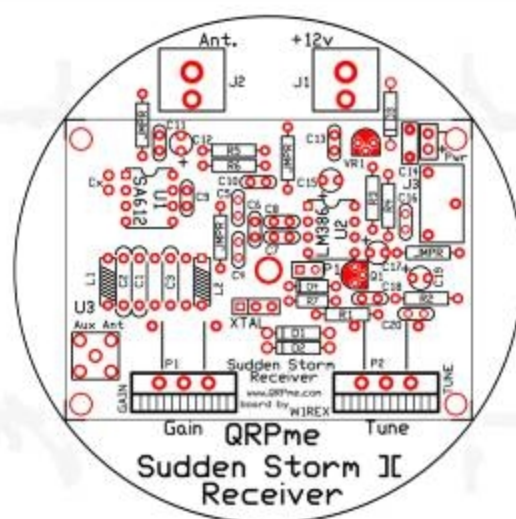
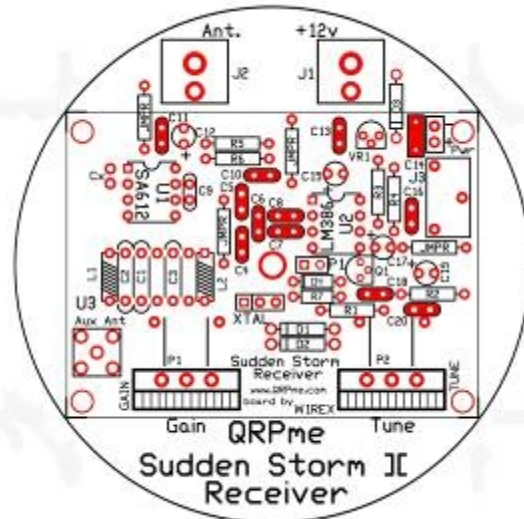
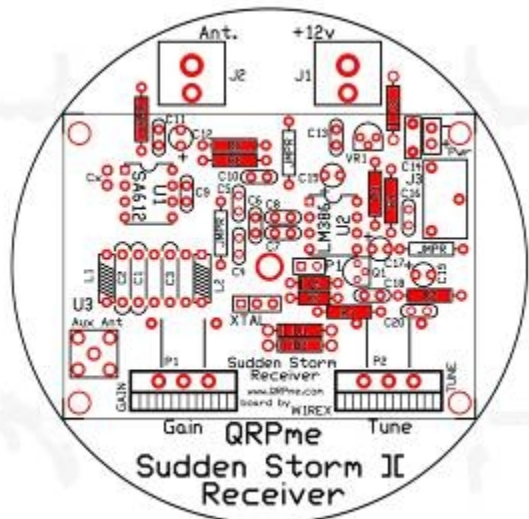

Now install the IC and crystal sockets.

U1, U2 = 8 pin DIP sockets

Install the sockets so that the little notch in the socket matches the notch in the silk screen pattern.

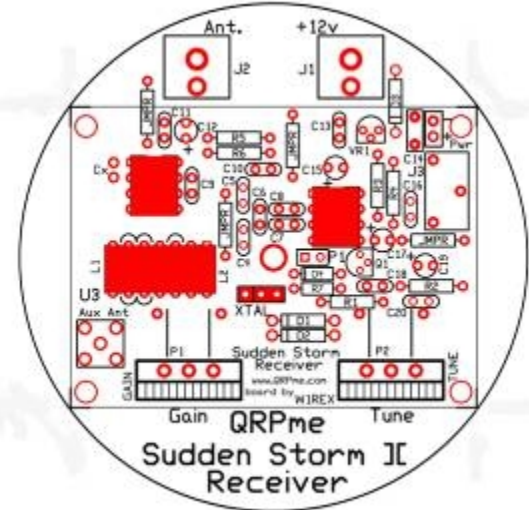

Snip off a 3 pin segment of the 8-pin SIP socket to use as the crystal socket. Solder it in place at the XTAL location.

The 4 small blue electrolytic capacitors are now installed.

C12, C17, C19 = 100uf

C15 = 10uf

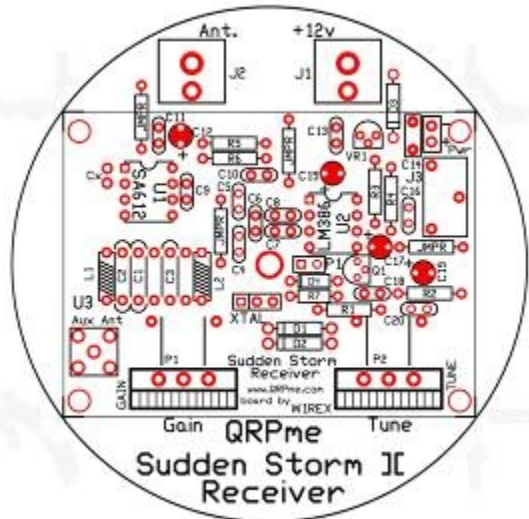

The 'clunky' connectors can now be soldered onto the board.

Please note that the AUX ANT and PWR connectors are optional and would be used when installing the Sudden Storm][kit in an Altoids or Zomboids tin.

J1, J2 are yellow RCA connectors
J3 is a stereo headphone jack
P1 is a 2 pin .1" spacing male Molex header.

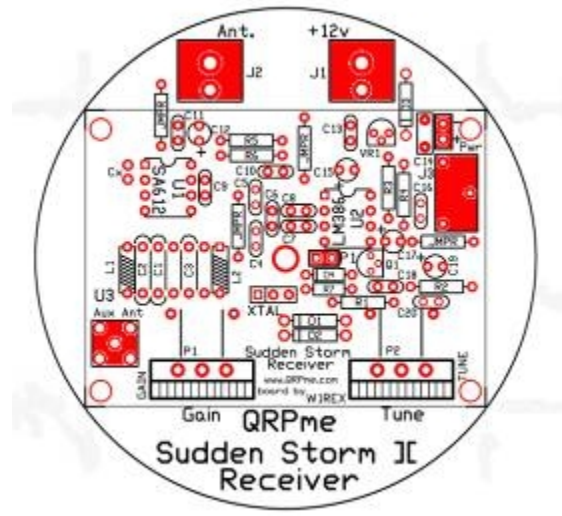

The thumbwheel potentiometers are next. Solder the 2 pots onto the board then bend them straight up. Small pieces of bare copper pcb material can be soldered in behind the pots to provide a stiffener for relieving operator stress on the pots while adjusting them.

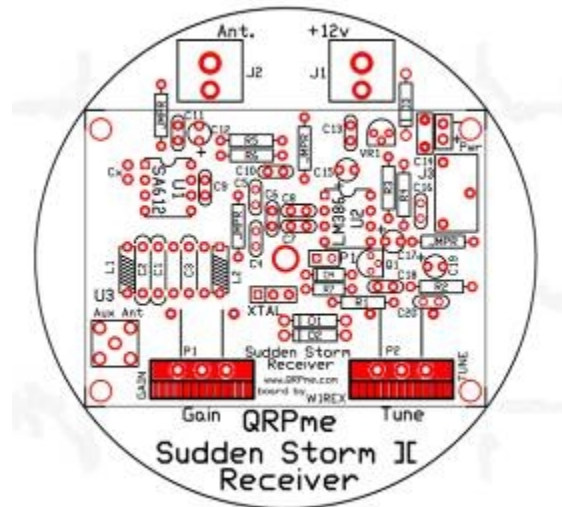

The bifurcated carrier is next. You have to be very careful soldering the parts onto the carrier. The plastic used for the carrier is easily melted so a GOOD heat sink should be used when soldering the parts. Use a small electronic vice, a binder clip or needle nose pliers with an elastic band around the handles to keep them closed as a make-shift heat sink for soldering. Clamp one row of pins in your heat sink device, install each part into its proper pair of pins and solder only the one side you have a heat

sink on. Make sure that you solder the connection quickly and follow the soldering operation with a nice long cooling breath to help keep the heat from melting the plastic. Don't hurry and try to solder all the pins in quick succession as this might cause excess heat to build up in the heat sink which might affect the plastic.

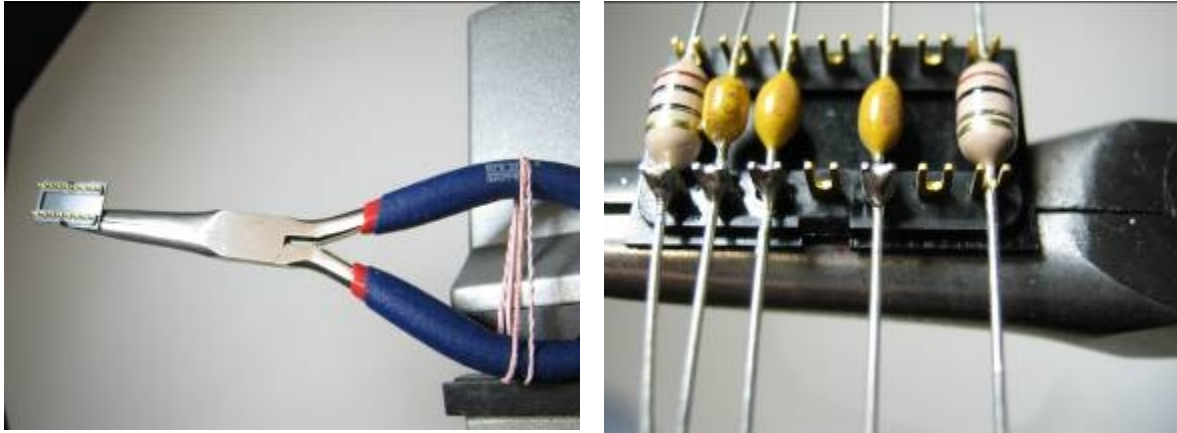

Once you solder the components on the heat sink side, turn the connector around and clamp the unsoldered side. Now you can solder the remaining connections and trim the excess leads. The tuning plug is now complete. The layout of the components from left to right is:

10 uH	(brn-blk-blk)
220 pF	(221)
68 pF	(680)
unused	
.01 uF	(103)
unused	
10 uH	(brn-blk-blk)

The IC carrier is used as a tuning plug providing a rough match between the antenna and the SA612 Gilbert cell mixer chip. A separate tuning plug is required for each band that you want to

use the receiver on. A table of suggested component values used for each band is shown below.

Band	C1	C2	C3	L1	L2
80m				.01uf	6.8 22uh
40m		68pf	220pf	.01uf	10 10uh
30m				.01uf	10 10uh
20m				.01uf	22 6.8uh

(as of right now C1, C2 would be the same for all 4 bands...although that might change with further experimentation.... W1REX)

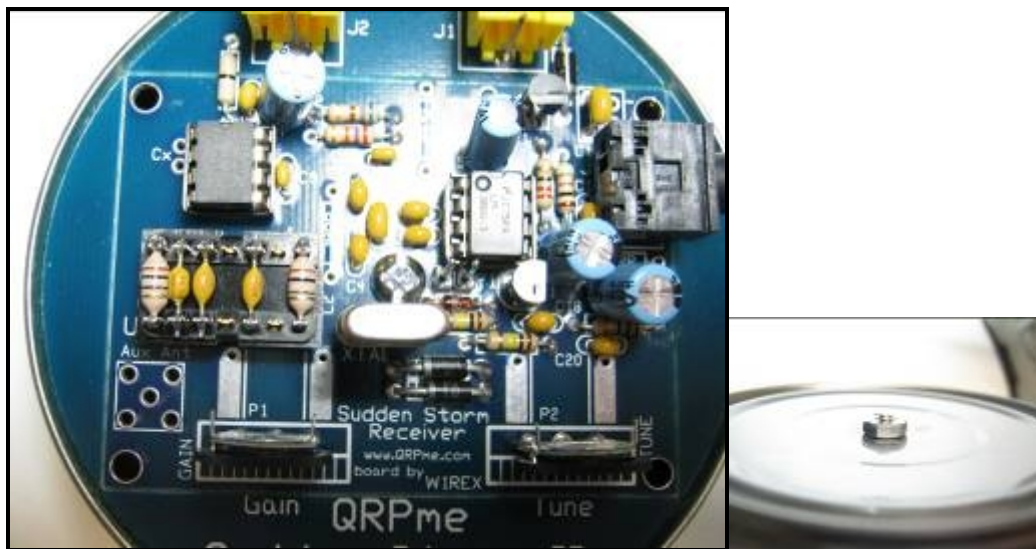

Mount the board on the can, insert the bolt down through the hole in the center of the board and out the hole in the bottom of the can. Add the nut and tighten to clamp the board to the can.

Don't over-tighten!



Congratulations!

You're done!