

## Memory Keyer for the Rockmite ][

The PicoKeyer is a single chip, automatic iambic Morse code keyer with two message memories. Perfect for portable or QRP operation or for integrating into transmitters or transceivers, its low power requirements and no need for external parts make it ideal for limited space applications or battery operation. These instructions detail the use of the RockMite / HiMite / Rockmite ][ compatible model.

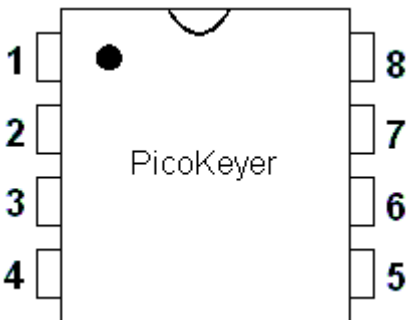

Pinout Information		
Pin	IN/OUT	FUNCTION
1	Power	Vdd (2.5 – 5.5 V)
2	OUT	Keying output
3	OUT	XTAL shift output
4	IN	Button input
5	OUT	Sidetone output / speed pot input
6	IN	DASH paddle input
7	IN	DOT paddle input
8	Power	Vss (Ground)

### Features of the PicoKeyer-RM

- Also useful as a direct drop-in replacement keyer chip for the RockMite or HiMite
- Two message memories, 100 characters each can be chained together
- Optional analog speed control potentiometer input
- Easy to use, one-button "menu" interface
- Works with any dual lever ("squeeze") or single lever keyer paddle, or straight key
- Setup and message entry using your paddle
- Speed adjustable from 5 to 45 WPM
- Variable pitch audio sidetone
- Adjustable weight
- Selectable iambic Mode A, Mode B, Ultimatic, straight key or "bug" keying modes
- Tune mode with hands-free constant carrier or 50% duty cycle dits
- Beacon mode with adjustable 0 – 99 second delay
- Memory "pause" allows manual insertion of RST or other information into a recorded message
- Paddle switching - select left or right handed operation
- Memory and parameter settings retained with power off
- Auto straight key detect, both memories available with straight key

## Installation

Install the Rockmite ][ keyer chip as described in the *Rockmite ][ Builders Guide*. Operation of the keyer is described in the following sections of this manual.

## Analog Speed Control

The PicoKeyer-RM for the Rockmite ][ is capable of using an external potentiometer to set the operating speed. This is completely optional – there are no parts needed if you want to stick with the traditional paddle speed control. For analog speed control you will need to install two fixed resistors and a potentiometer, connected as shown:

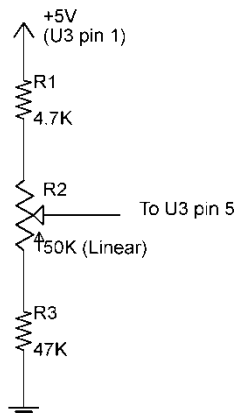

After the resistors are installed, enter the pot calibration function (setup menu item “L”). The keyer will send “HI”; set the speed pot to its fully clockwise position and tap either paddle. The keyer will then send “LO”; set the pot fully counter-clockwise (or anti-clockwise, if you’re in the UK) and tap either paddle. The speed pot settings will be saved when you tap the button to exit the menu.

With this setup, turning the pot to its full counter-clockwise position will set the speed to the default menu speed setting (the “set” speed). This way you can set your preferred operating speed via the setup menu, and always be able to return to that speed simply by turning the speed pot all the way down.

*Note: See page 6 for specific connection points to the Rockmite ][ PCB.*

## Operating with the PicoKeyer

One momentary pushbutton switch input is used just like the original RockMite configuration. A single, brief tap of the button will switch the oscillator offset the same as the normal RockMite chip. There are a couple of significant differences, of course! The PicoKeyer-RM has a more extensive setup menu and two message memories that can be programmed with up to 100 characters and word spaces each.

Tapping the dot paddle while pressing the button briefly (less than half a second) will send the contents of Message Memory 1; tapping the dash paddle while pressing the button briefly will send the contents of Message Memory 2. Holding in the pushbutton more than half a second will tell the keyer to enter setup mode. In setup mode the keyer will use the sidetone only and will not key the transmitter. As you hold in the button the keyer will cycle through the available menu choices. You can simply release the button when you hear letter corresponding to the item you want to check or change. Once you finish with that menu item, press and immediately release the button to exit the menu, or hold the button down to advance to the next item.

A different mode is available for the setup menu. If you select “Paddle mode” (PDL) for menu option “C”, you will hear a “?” prompt when you enter setup mode. At that point you can simply send the letter corresponding to the setting you wish to review or use. If you enter an incorrect command, you’ll get a response that lets you know the keyer didn’t understand what you sent. It’s faster, but you need to remember the menu options or have a “crib sheet” handy.

Below is a quick comparison of the two setup modes.

“Button” mode (BTN)	“Paddle” mode (PDL)
<b>How it works:</b> Hold down the button until you hear the menu item you want to change, then release.	<b>How it works:</b> Wait for “?” prompt, then send letter of the menu item you want to change.
<b>Example:</b> To change the weight, hold the button down. You will hear “S”, “U”, “M”, “W” -- release the button when you hear “W”.	<b>Example:</b> To change the weight, hold the button down until you hear “?”. Send “W” with the paddle.
<b>Making Changes:</b> The keyer will send the current weight setting, and you adjust using the paddles (same for either mode).	
<b>When finished:</b> Tap the button to exit the setup menu, or hold the button for the next menu item.	<b>When finished:</b> Tap the button for a “?” prompt. To exit setup mode, tap the button again or send “SK”.

## Straight Key Mode

The PicoKeyer will automatically detect and use a straight key when one is plugged in. When power is applied, the PicoKeyer looks to see if either paddle input is shorted to ground. If one is, the other input is assumed to be a straight key. This way you can plug in a straight key wired to a mono plug and use it without any changes or adjustments. Be aware that while the menu will still function, many parameters will not be adjustable (and would not apply to a straight key anyway). You will not be able to record messages while using a straight key. Note that you must plug in the straight key, THEN turn power on for this to work properly.

Both message memories will be available, which must have already been recorded using a paddle. Message 1 will be sent when the button is pressed and the key is tapped and released while the button is still held. Message 2 will be sent if the key is held down after the button is released. You may want to practice a little to get the hang of it, but after a little practice it will be easy. Remember:

Button down – key down – key up – button up for Message 1;

Button down – key down – button up – key up for Message 2.

## Reset

Should it become necessary to reset your keyer chip to its default state, you may hold both paddles while powering on. The keyer should switch to 13 WPM, normal sidetone and sends “**RESET?**”. Release both paddles as soon as the keyer begins sending. If you are sure you want to reset the keyer, tap either paddle. This should have the same effect as menu option “F” – all settings and memories will be returned to their original state. If you have a speed pot installed, you will need to re-calibrate using the L menu setting.

## Support

Should you need support, have questions, have feature requests or bug/problem reports, please feel free to contact me via email at [w1rex@megalink.net](mailto:w1rex@megalink.net). I will make every effort to respond as quickly as possible.

## Warranty

All parts are tested and are guaranteed against defects for one year from date of purchase. This warranty does not cover damage due to incorrect assembly, improper soldering or wiring, overvoltage, static damage or other misuse or abuse. If you have problems, please contact me via email to arrange for an exchange or replacement part.

**Cut Numbers:** Responses to interrogations from some functions use cut numbers, e.g., T = 0 and N = 9.

## Menu Functions

S	<p><b>Speed:</b> The keyer will send the current speed setting. If you have a speed control pot installed, and if the pot is set for something other than the “set” speed, you will hear both speeds – for example, “13 / 20” if you have the “set” speed at 13 WPM, but the speed pot is set to 20 WPM.</p> <p>To change the speed up or down one WPM simply tap the appropriate paddle. The dot paddle will decrease the speed; the dash paddle will increase it. Holding either paddle will continuously increase or decrease the speed, with a dash or dot sent at the new speed for each step. Speed may be set from 5 to 45 WPM.</p>
U	<p><b>Tune mode:</b> Tune mode is used to send either a steady carrier or a series of dits for adjusting or testing your station equipment. While in tune mode, the paddles act as on/off toggle switches. Tap the dash paddle to turn a steady carrier on or off. <i>Use with caution</i> - don’t overheat the Rockmite ][ final PA! Tap the dot paddle to start or stop a continuous stream of dits. This gives you a 50% duty cycle signal that is preferred by some operators as a way to tune up with less stress on final PA, tuner and antenna components.</p>
M	<p><b>Memory:</b> Two message memories are available, M1 and M2. The dot paddle is used to select Message 1, while the dash paddle selects Message 2. When you enter Message mode, message M1 will be the default selection. You have a choice of actions available to you when in memory mode, selected by sending a single character from your paddle:</p> <p>Send the number 1 or 2 to select a message memory. The keyer will respond by sending /or 2 to confirm.</p> <p>Send <b>P (Play)</b> to listen to the contents of the currently selected memory. The keyer will play the message, followed by the Morse prosign <i>AR</i> and the message number.</p> <p>Send <b>R (Record)</b> to record a new message. If a message already exists it will be erased and replaced. The keyer will respond with <i>K</i> to let you know it is in record mode. Enter your message, with exaggerated word space but normal spacing between characters. If you make a mistake when recording the message, just send 8 (or more) dits and the keyer will backspace one word. You will hear a single dit to confirm this (two dits means you are at the beginning of the message). Tap the setup button once when you are finished recording. The keyer will send <i>R</i> and the message number to indicate the end of the message. You can then <b>Play</b> the message back.</p> <p>Send <b>C (Continue)</b> to add onto or edit the message. The keyer will play the current message, then enter Record mode. You can backspace over existing words if needed.</p> <p>You can use the <b>R, P</b> and <b>C</b> commands to listen and change your message until you're satisfied. Each memory can hold up to 100 characters. If you send something other than 1, 2, P, R, or C the keyer will respond with “?” and let you try it again.</p> <p>Important note: The slant bar character “/” is used for embedded commands. If you use a slant bar character (/) as part of your message, you must use two of them together. For example, if I want to send “<b>WIREX/QRP</b>” I will need to store “<b>WIREX//QRP</b>” in the message.</p> <p>Several embedded commands may be used in messages. When playing back a message in setup mode you will hear the command itself, not its effect – message chaining, QSO numbers, pause and beacon mode are inactive while in setup mode. For example, you will hear /R instead of the word to be repeated.</p> <p>The embedded command <b>/R</b> will repeat the last word, including the word space after it. This can save a lot of memory space, since each <b>/R</b> takes up only two character positions in memory. For example, to send a 3x3 CQ, you can simply store “<b>CQ /R/RDE W5USJ/R/RK</b>”. This can save a lot of memory locations.</p>

	<p>You can “chain” the message memories together. This should be done only at the end of a message. <b>/1</b> will immediately play Message 1, and <b>/2</b> will immediately switch to Message 2.</p> <p>To insert a pause in the message, use the embedded command <b>/P</b>. This will cause the message to pause while you manually send information such as QSO number, RST, etc. The message will resume as soon as you stop sending for more than one word space. <i>Hint: If you use <b>/P</b>, store it immediately following the preceding characters without a word space. In other words, store “UR RST/P ...” instead of “UR RST /P ...”. This prevents you starting to send before the word space completes, which will terminate memory playback completely.</i></p> <p>To use BEACON mode, insert the embedded command <b>/B</b> at the end of your message. This will cause the keyer to delay for the number of seconds set with the B parameter (see below) and re-send the message. You can terminate beacon operation by tapping either paddle or the button. <i>This is really handy for calling CQ!</i></p> <p>To insert a steady carrier use the command <b>/Cn</b>, where <b>n</b> is the number of seconds you want to send the carrier.</p> <p>To send the QSO number and increment it by one, use the <b>/QI</b> command.</p> <p>To send the current QSO number and NOT increment it, use the <b>/QN</b> command.</p> <p>To re-send the last QSO number, use the <b>/QR</b> command.</p> <p>To temporarily increase sending speed by 1 WPM, use the command <b>/SU</b>.</p> <p>To temporarily decrease the sending speed by 1 WPM, use the command <b>/SD</b>.</p> <p>To insert an extra word space, use the special prosign “<b>IM</b>” (-----).</p>
W	<p><b>Weight:</b> The keyer sends the current weight setting and waits for input. Again, the dot paddle may be used to decrease the weight or the dash paddle to increase it. Weight can be set anywhere from 1 (50% "light") to 5 (normal) to 9 (50% "heavy").</p>
P	<p><b>Paddle Selection:</b> Simply hit whichever paddle you want to use for DITs. This can be used to switch from right-handed to left-handed operation without swapping wires.</p>
B	<p><b>Beacon Delay:</b> The keyer sends the current beacon repeat interval and waits for input. Use the dot and dash paddles to decrease or increase the setting. Delays can be set from 0 to 99 seconds.</p>
A	<p><b>Audio Tone:</b> The keyer will send a series of dits at the selected sidetone audio frequency. Use the paddles to increase or decrease the audio frequency as desired.</p>
K	<p><b>Keying Mode:</b> The keyer will send the current keying mode:</p> <ul style="list-style-type: none"> <li>“A” for iambic Mode A</li> <li>“B” for iambic Mode B</li> <li>“U” for Ultimatic</li> <li>“G” for Bug mode (automatic dots, manual dashes)</li> <li>“S” for straight key mode, dot input is straight key and dash input is ignored.</li> </ul> <p>You can use the key or paddle to switch between modes. In “Bug” mode, dots are made automatically with the correct spacing and length with one paddle input, while dashes are made manually with the other. If straight key mode is selected while using a paddle, either paddle input will key the transmitter.</p>
C	<p><b>Command mode:</b> Keyer sends “BTN” or “PDL” and waits. Tapping either paddle will toggle between Paddle commands (PDL) and Button command mode (BTN).</p>
L	<p><b>Potentiometer Calibration:</b> Sets the high and low limits of the speed control potentiometer, if installed. <i>See the “Analog Speed Control” section for details.</i></p>
F	<p><b>Factory Reset:</b> Keyer sends “?” and waits. If you tap either paddle the keyer will be completely reset. All message memories will be wiped, and default settings will be restored (5 WPM, normal paddle orientation, iambic A mode, 5 second beacon delay, 800 Hz sidetone).</p>
V	<p><b>Firmware version:</b> Keyer sends the version number of its program.</p>

## A Note From Rex, W1REX

This keyer chip was designed by Dale Botkin, N0XAS, at Ham Gadgets specifically for the RockMite transceiver. The RockMite was designed and WAS produced by Dave Benson, K1SWL. It is also used in the updated 'Rockmite II' transceiver by Rex Harper, W1REX at QRPme. If you don't have at least one of these little rigs, you're missing out on some of the real fun of ham radio. Visit [www.QRPme.com](http://www.QRPme.com) to find out more about the Rockmite II.

I'm always interested in hearing your feedback. If you find something that doesn't work quite right, or if you have an idea for a new feature, let me know via email to [w1rex@megalink.net](mailto:w1rex@megalink.net).

PicoKeyer-RM Menu Quick Reference			
S	Speed	A	Audio tone
U	U Tune mode	K	Keying Mode (A, B, Umatic, buG, Straight)
M	Message Memory	C	Command mode
W	Weight	L	Potentiometer Calibration
P	Paddle reverse	F	Factory Reset
B	Beacon delay	V	Firmware Version

## Analog Speed Pot – Connections to PCB

### PCB Ver 3

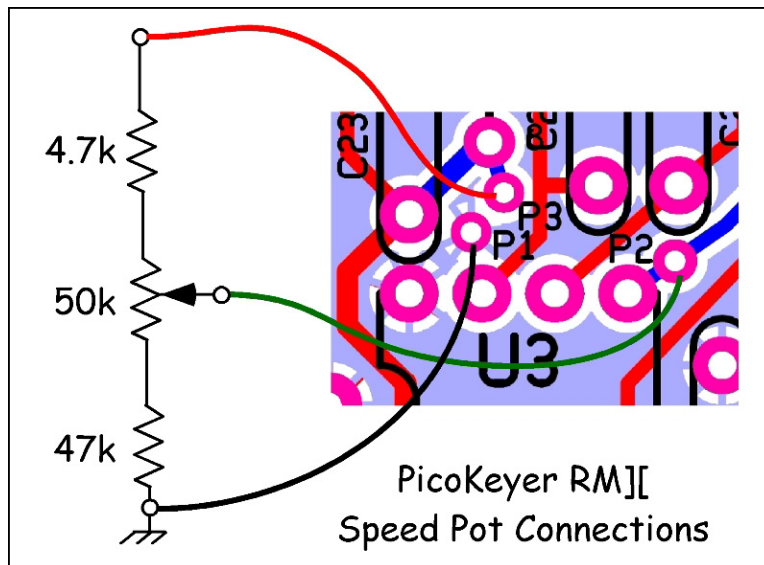

On V1 PCBs, solder to a pad that has the proper signal as that used for the connections to the version 2 boards, e.g., C23 pad for P3, C8 pad for P2 and any ground pad for P1.

Be sure to carefully scrape the solder mask away from pads P1, P2 and P3 on the bottom of the board before soldering.